

Drawing 26.
S Panel Roof PIR; MWF; EPS - strip skylight

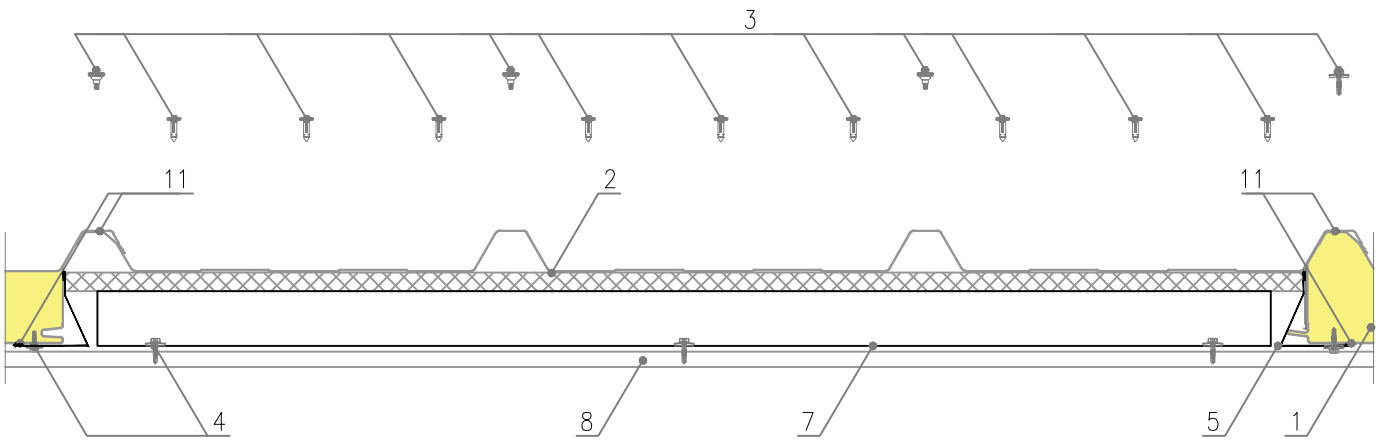

Joint on the longer side of the roof panel with skylight on the side of the roof ridge

Joint on the longer side of the roof panel with skylight on the side of the eaves

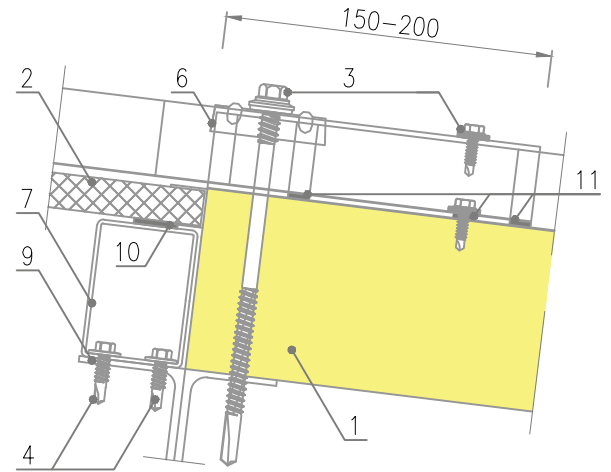
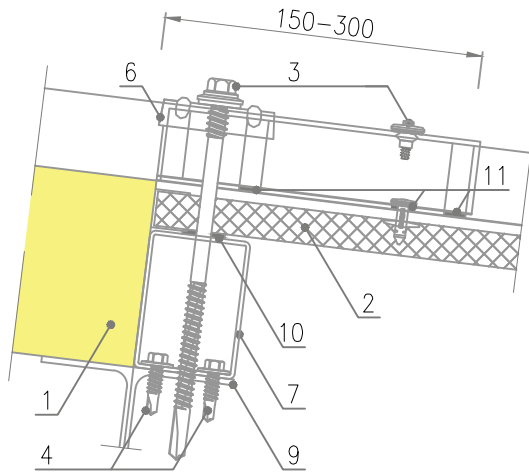

Assembly direction

Longitudinal joint of the skylights

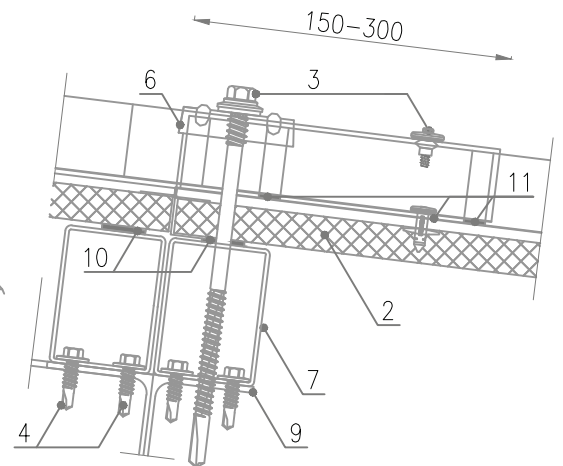
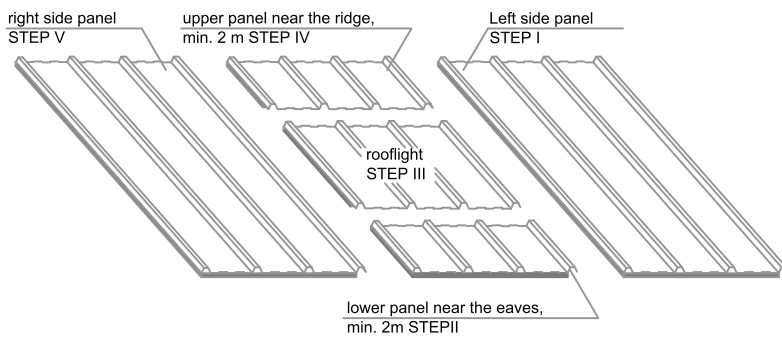

1. S Panel Roof PIR; MWF; EPS panel
2. Polycarbonate panel with resin and glass facing
3. System screws and rivets - every 300 mm on the edges
4. Drive screw with EPDM washer
5. Ob-44 flashing
6. L-03 fastener

7. Spacer
8. Purlin
9. Substructure, if purlins width < 100 mm
10. Self-adhesive PES sealing tape
11. Butyl tape